

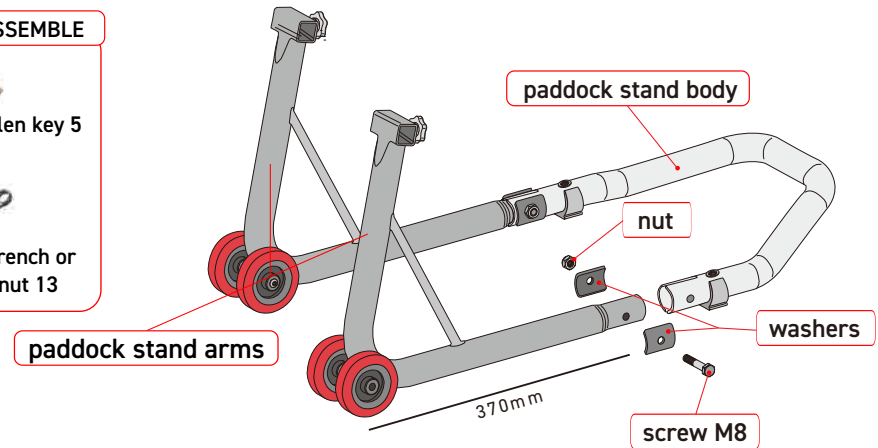

1. Assembly of the paddock stand

The paddock stand is delivered disassembled and some very basic assembly is required. First insert the **paddock stand arm** into the **paddock stand body** and then use the included **washers, nut, M8 screw** and size 13 wrench (not included) to attach it. Repeat with the other **paddock stand arm**.

TOOLS TO ASSEMBLE



2. Adapter installation and width setup

To install or adjust the adapter unscrew the **adapter locking bolt** and insert the adapter. The depth of the adapter can be adjusted to fit width of specific motorcycle.

Place the paddock stand with adapters in line with the motorcycle swing arm or front forks to measure and adjust the adapters properly and then fix their position by tightening adapter locking bolt by hand.

For video instructions visit our youtube channel SEFIS moto

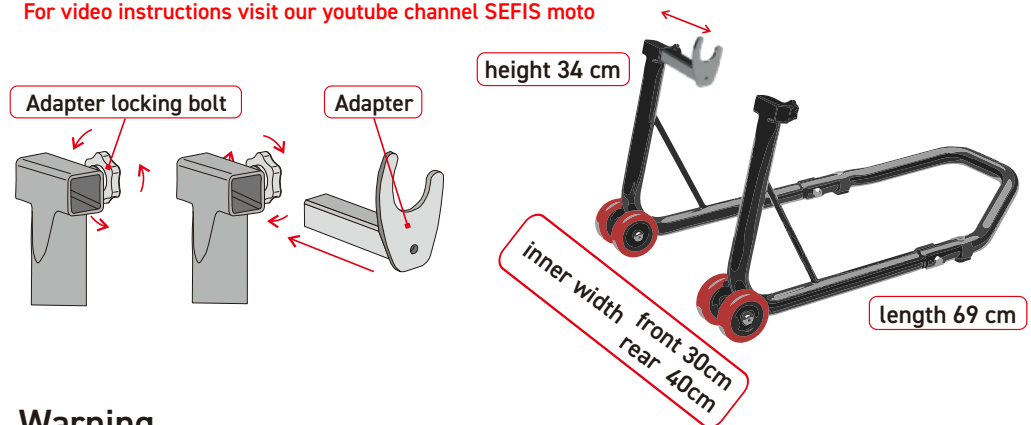

3. Warning

When using two paddock stands always lift rear wheel first and then proceed to lift the front wheel. It is advised to not lift motorcycle alone as the safest use is for one person to hold the motorcycle while another person lifts it using the paddock stand. Prior to the use always inspect technical condition of the paddock stand and the adapter set up. Keep away from children when in use. Maximum carrying capacity of single paddock stand is **200 kg** for maximum motorcycle weight of **400 kg**.

